

PF 42.500 | PFA 40.000

ECOOL FILTERFAN | EXHAUST FILTER 125–160 m³/h



- installation size 4, air flow rate up to 160 m³/h
- two performance classes, cut-out compatible
- system of protection IP 54 and IP 55, NEMA type 12
- UL, cUL approval
- UV-resistance (IP 55 version)
- cut-out compatible with installation size 4 from the 3rd Generation

PRODUCT		PF 42.500					Unit
ARTICLE NO.	IP 54	11642101055	11642151055	11642851055	11642801055	11642701055	
ARTICLE NO.	IP 55	11642103055	11642153055	11642853055	11642803055	11642703055	

DATA		AC 50 60 Hz		DC			
Rated voltage ±10 %		230	115	12	24	48	V
Unimpeded airflow	IP 54	125 138					m³/h
	IP 55	145 160					
Airflow rate in comb. with exhaust filter	IP 54	93 102					
	IP 55	109 113					
Power consumption		18 17		6	4.7	4.6	W
Current consumption		0.12 0.1	0.25 0.25	0.5	0.2	0.1	A
Noise level according to EN ISO 3741		40 43		40			dB (A)
Weight		1.18		0.92			kg
Type of connection		spring-type terminal					
Fuse		6					A
System of protection according to EN 60529 / UL 50	IP 54	NEMA type 12 - standard filter					
	IP 55	NEMA type 12 - fluted filter					
Filtration efficiency according to EN 779	IP 54	> 90					%
	IP 55	> 90					%
Filter mat quality class according to EN 779	IP 54	G 4					
	IP 55	G 4					
Duty cycle		100					%
Bearing type		ball bearing					
Service life L ₁₀ (+ 40 °C) ¹		40000	42500	57500	70000		h
Temperature range		-40 ... +55 -40 ... +131					°C °F
Design (housing and protection against accidental contact)	IP 54	made of injection-moulded thermoplastic, self-extinguishing, UL 94 V0					
	IP 55	additional: UV-resistant					
Colour		RAL 7035 different colours available on request					

ACCESSORIES		ARTICLE NUMBER
Exhaust filter	gray	11740001055
Exhaust filter	black	11740001050
Spare filter mats	5 pieces	18611600032
Thermostat		17121000000
Hygrostat		17207000000
Rainhood in stainless steel		18102000017

For additional models, options and voltages visit www.pfannenber.com or contact us directly.

¹ fan failure is defined as being when the current and speed deviate or the operating noises are out of the ordinary

Cooling capacity performance curves

Static pressure performance curve

PF 42.500 IP 54

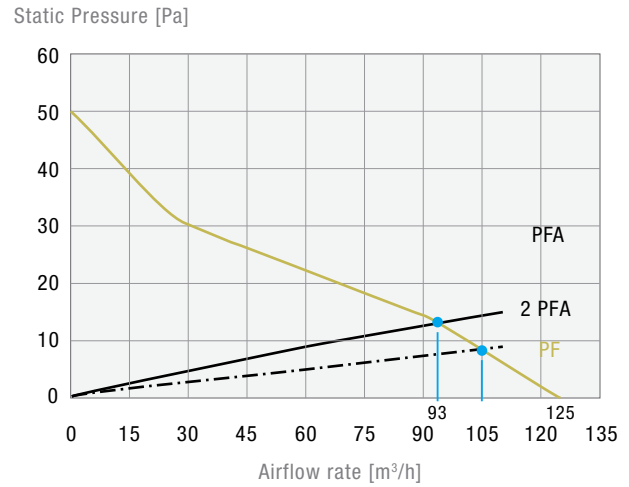
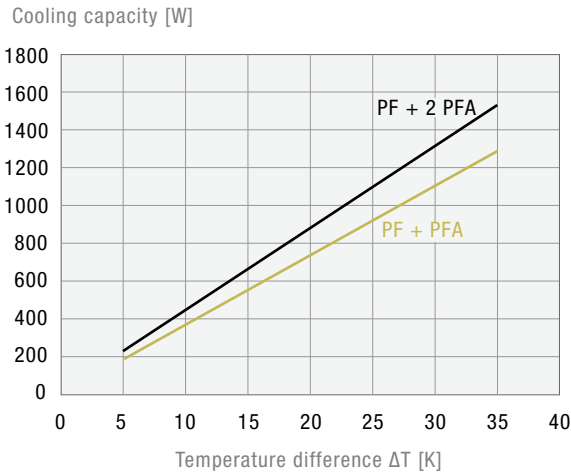

PF 42.500 IP 55

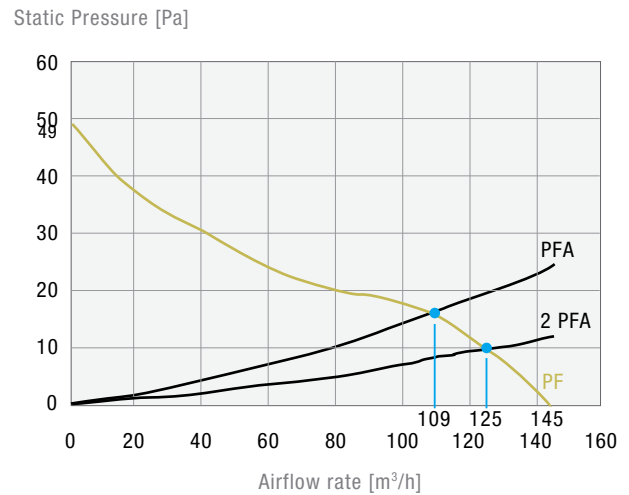
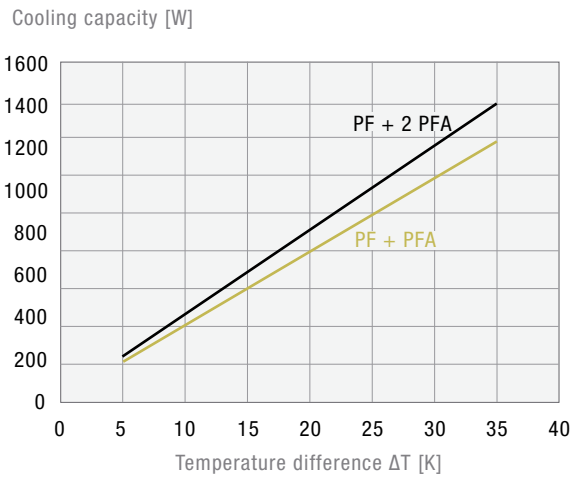

Dimensions

mm	PF 42.500	PFA 40.000
X	252	252
Y	252	252
Z1	6	6
Z2	97	38
A¹	223	223
B¹	223	223

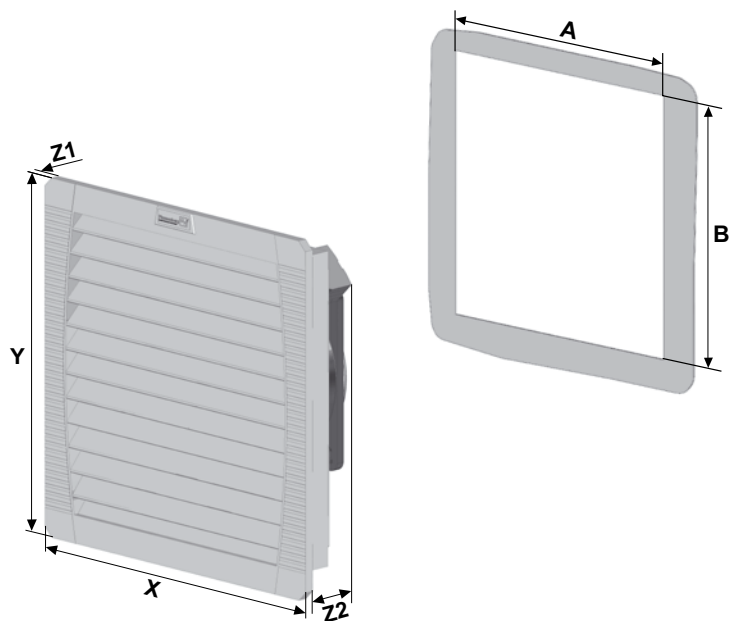

¹ for material thicknesses up to 2 mm
+ 1 mm for thickness of material > 2 mm ≤ 3 mm